

# CONCRETE QUARTERLY

AUTUMN 2017 | ISSUE NUMBER 261



## FACTORY FLARE

AHMM takes the industrial aesthetic to new heights at the White Collar Factory

## CENTRE OF ATTRACTON

Rick Mather Architects transforms Centre Point from neglected icon to West End des-res

## MODERN LIFE IS RABBISH

How Bennetts Associates revived exposed concrete for the 21st century



## INSPIRATION

### 4 COLLAR INSTINCT

Have Derwent London and AHMM created the perfect concrete workspace?

### 8 BACK TO THE POINT

Rick Mather Architects and Conran and Partners breathe new life into Richard Seifert's West End masterpiece

### 11 WAFFLY GOOD

Restored waffle slabs take centre stage at TateHindle's ingenious office refurbishment

## FOCUS

### 12 MASTERS OF MASS

How Bennetts Associates convinced clients to stop worrying and love exposed concrete

### 16 FLOORING IT

Essential steps to the perfect polished floor

## STRUCTURES

### 18 DESIGNING CONCRETE BASEMENTS

There are many ways of constructing basements – here are the key points to consider

## RETRO CONCRETE

### 15 LASTING IMPRESSION

Gavin Miller celebrates underwater Roman concrete, Perret's Parisian apartments and the fluidity of Niemeyer's houses

## DON'T MISS AN ISSUE

Catch up with the latest issues of Concrete Quarterly – as well as our archive stretching back to 1947 – at [www.concretecentre.com/cq](http://www.concretecentre.com/cq)



**On the cover:**  
White Collar Factory in London by AHMM.  
Photo: Rob Parrish  
**Produced by:**  
Wordmule  
**Designed by:**  
Nick Watts Design



The Concrete Centre is part of the Mineral Products Association, the trade association for the aggregates, asphalt, cement, concrete, dimension stone, lime, mortar and silica sand industries.  
[www.mineralproducts.org](http://www.mineralproducts.org)



**Guy Thompson**  
Head of architecture, housing and sustainability, The Concrete Centre

## The rise of white collar concrete

**As we mark the 70th anniversary of Concrete Quarterly's first issue, it's been an opportunity to reflect on the changing place that concrete has held in the architectural pallet over the last seven decades.**

When our story begins in 1947, huge quantities were being poured on building sites and in factories as part of the post-war rebuilding effort, and over the following decades, concrete was the chosen aesthetic as architects and engineers sought to create new types of building for a new age. Then came the lean years of the 1980s and early 1990s, before the renaissance we enjoy today got into full swing.

So, it's rather fitting that our projects for this issue tell a story of their own, a snapshot of concrete's rise, fall from grace and current resurgence. Richard Seifert's Centre Point tower in London's West End is a neglected 1960s icon, a guilty pleasure for many, now proudly reinvented as luxury residential – Rick Mather Architects' strategy was to treat it as a heritage building. AHMM's White Collar Factory on the edge of the City exemplifies the proliferation of exposed concrete surfaces in current office buildings, deployed to create a trendy industrial aesthetic and for the natural cooling potential of thermal mass. And a short stroll across the hipster heartland of Hoxton, 45 Folgate Street is an unloved 1980s concrete-framed office brought back into use, with its concrete waffle ceilings not only exposed but lit up as a star design feature.

The underlying theme here is that of resilience: of concrete structures themselves, and of their ability to cushion owners and occupants from extremes of temperature and weather, noise and fire, and – thanks to their inherent flexibility – from the inevitable cycles of the property market.

Both Centre Point and 45 Folgate Street demonstrate the adaptability of existing structures, offering not only heritage charm but a much lower embodied energy than a complete redevelopment would have done. Centre Point's concrete had in fact weathered incredibly well over its 50 years in this polluted part of the capital, while 45 Folgate Street's waffles mostly required only a brush. Derwent London and the designers of the White Collar Factory took the lessons from the former industrial buildings that are so popular with today's millennial workers, and embedded them in a new build – starting with an open, high-ceilinged, robust concrete frame. Whether it too will stand the test of time remains to be seen, but from where I'm standing, the auguries are good.

**BOTH CENTRE POINT AND 45 FOLGATE STREET DEMONSTRATE THE ADAPTABILITY OF OLDER STRUCTURES**



## THAT 70 SHOW

**"With peace came concrete."** So begins a free exhibition at the Building Centre in London marking 70 years since the first issue of Concrete Quarterly was published. After the Second World War, Europe faced reconstruction on an unprecedented scale. But it wasn't about simply rebuilding what had been: this was a chance to create a new society. Architects and engineers led the charge into the future, designing schools, hospitals, factories, new towns, entirely new ways of living. As the modern world rose from the rubble, CQ was founded to record it. The exhibition runs until 31 October.



**Stirling contender**

City of Glasgow College's monumental City Campus by Reiach and Hall and Michael Laird Architects is one of six projects shortlisted for the 2017 RIBA Stirling Prize. It is clad in crisply detailed white precast concrete.



Photos: Keith Hunter; Jeff J Mitchell/Getty Images; KAZA Concrete; Paul Osborne/Compound Eye



**Forth first**

The 1.7-mile Queensferry Crossing over the River Forth has opened to traffic. The £1.35bn project included the world's longest continuous underwater concrete pour – 16,869m<sup>3</sup> over 15 days.

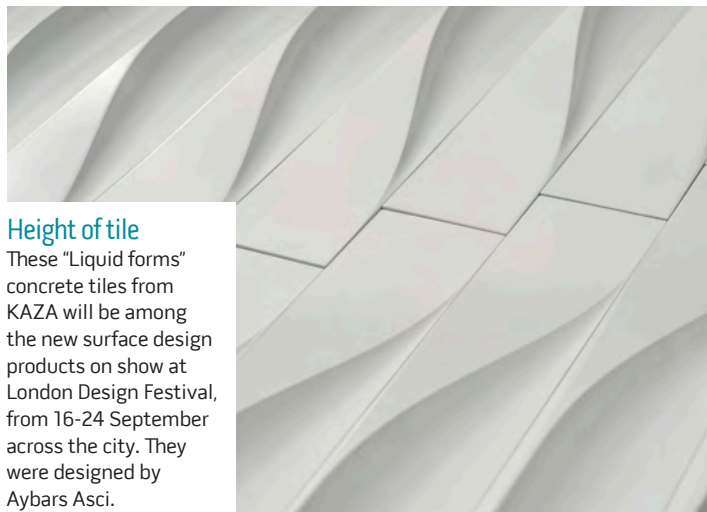

**Height of tile**

These "Liquid forms" concrete tiles from KAZA will be among the new surface design products on show at London Design Festival, from 16-24 September across the city. They were designed by Aybars Asci.

**Rough diamond**

A campaign is growing to save Michael Blampied's 1971 Welbeck Street car park in central London from demolition. The building, which is scheduled to make way for a new hotel, features an elaborate facade of prefabricated concrete diamonds.



**NICE WORK ...**

As part of the 70 Years of Concrete Quarterly season, the evening lecture, "The Workplace, Past and Present", will focus on two pioneering London projects. Rick Mather Architects will present a preview of the remodelling of Centre Point (left), while AHMM and AKT II will explain the innovative design approach behind the White Collar Factory (right).

**The lecture takes place from 6-8pm on 20 September at the Building Centre in London. To book a place, visit [www.concretecentre.com](http://www.concretecentre.com)**



Images: Conran and Partners; Rob Parrish



# COLLAR INSTINCT

With its Silicon Roundabout "Factory", AHMM takes the trend for sustainable, flexible, industrial-style office spaces to its logical conclusion, writes Tony Whitehead







**Developer Derwent London has done more than most to popularise the factory aesthetic for London's commercial buildings.** Characterised by high ceilings, an exposed frame and visible services, among the earliest examples was its 2003 refurbishment of the Tea Building in Shoreditch, followed by the Johnson Building in Hatton Garden in 2006. Of the latter, Derwent London's Matt Massey recalls: "Letting agents would come round and ask when it was going to be finished – when was the plasterboard going in? How things have changed ..."

Delighted with the growing popularity of their projects, Derwent London attempted to analyse what had gone right. As Massey, senior project manager, puts it: "Why did these old industrial buildings made such great office spaces long after they were designed for another purpose entirely? What they had in common was a big, robust, often concrete frame. They were future-proof because the frame could take a lot of knocking about as the building was put to different uses."

White Collar Factory, a 17-storey new-build office building situated on Old Street's "Silicon Roundabout" on the edge of the City, is the latest and perhaps purest expression of the style pioneered by Derwent London and its partner, architect Allford Hall Monaghan Morris.

Much of its in-situ concrete construction – including columns, walls, cores and ceilings – is in clear sight, and the concrete finishes, with timber markings and tie holes visible, tell the story of its construction. Particularly striking is the floor-to-ceiling height. "This is one of the features of industrial-style buildings that tenants really love," says Stephen Taylor, associate director with AHMM. "Here we have a 4m floor-to-floor height, incorporating a 350mm reinforced concrete flat slab and a 150mm raised floor. That leaves 3.5m floor-to-ceiling – considerably more headroom than a standard office, which has more like 2.7m."

With so much visible concrete the mix was of paramount importance. The construction team aimed for (and achieved) an Outstanding BREEAM rating, so 50% of the cement was replaced with ground granulated blast furnace slag (GGBS) to reduce the carbon content. But, says Taylor, the GGBS resulted in a "whitish" finish: "We wanted a warmer, more traditional concrete look, so 200kg/m<sup>3</sup> of PFA (pulverised fuel ash, now known as fly ash) was added to darken the mix." The PFA also contributed to the recycled aggregate content.

The final recipe was only arrived at after casting a dozen 1m<sup>2</sup> medallions of various mixes, and then constructing a pair of 3m-high mock-ups of the two preferred options: "These also allowed us to try out working joints and corner details as well as test the

---

**WE HAVE A 4M FLOOR-TO-FLOOR HEIGHT. THIS IS ONE OF THE FEATURES OF INDUSTRIAL-STYLE BUILDINGS THAT TENANTS REALLY LOVE**





**LEFT** The building is 17 storeys – but could have fitted an extra two floors with conventional floor-to-ceiling heights

**RIGHT** The stripped-down style has been quick to attract tenants

**OPPOSITE LEFT** Miles of plastic pipework embedded in the floor slabs contribute to the passive cooling strategy

**OPPOSITE RIGHT** A double-height space draws light into the building

**OPPOSITE BOTTOM** Both cores were built using jump-form construction

**PROJECT TEAM**

**Architect** AHMM  
**Structural engineer** AKT II  
**M&E engineer** Arup  
**Main contractor** Multiplex  
**Concrete contractor** Dunne Group

effects of different species of timber formwork.”

Central to how the building works is the flat slab. Its thickness, says Taylor, is principally to enable it to cope with spans of up to 12m (see box). Slimmer ribbed slabs or post-tensioned solutions were considered, but rejected for several reasons. “The 350mm helps give the building the thermal mass we wanted to help it stay cool in summer and warm in winter. We also wanted a clear, flat soffit to make it easy to fit – and then refit in the future – services like lighting and sprinklers.”

The passive cooling offered by the slabs is boosted by miles of plastic water pipes embedded within it. To incorporate the pipework, the first layer of reinforcement was laid on tables over a plywood deck. The pipes were then tied to the reinforcement and a second layer of reinforcement placed above that. Before the slab was poured, the pipes were pressurised with air to make sure that they weren't leaking, and also to stop them being crushed by the concrete.

Taylor admits that the idea of a pipe-cooled slab is hardly new – it was employed in the early 20th century by the American architect and concrete

enthusiast Frank Lloyd Wright. “Unfortunately his pipes leaked because they were made of metal. Ours don't.”

And unlike Wright's water pipes, those at White Collar Factory also benefit from an advanced building management system (BMS) to control the water temperature. Water can be heated if necessary in winter and the coolness varied in summer for slight or vigorous chilling. Five sensors on every floor monitor slab temperature and air humidity to prevent condensation, and the BMS incorporates weather forecasts to allow for the time lag inherent in any thermal mass-based temperature-control system.

Little of this sophistication is apparent to the visitor, however. The soffits have a simple finish revealing the standard plywood boards used for the decking. Similarly raw – or apparently so – is the horizontal timber-marked plank pattern visible in the concrete around both the cores and the ground-floor external walls. But while this may look like timber marking, it is not: the pattern was in fact created using a rubber form liner inside standard plywood shuttering. “We did this because

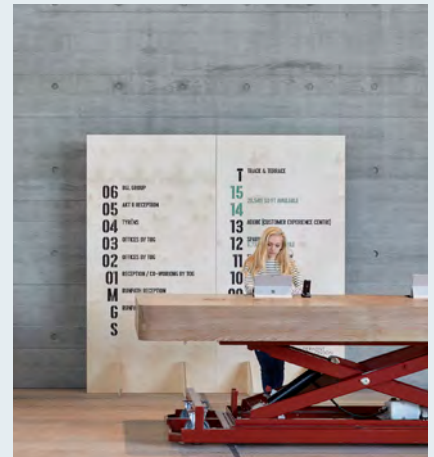

High space, high value

White Collar Factory's 3.5m floor-to-ceiling height is rare for a reason: it reduces the number of floors. So why would a developer interested in net lettable space choose to build the White Collar Factory way?

“It's true that we could have fitted in another two floors had we gone for standard heights,” agrees Derwent London's Matt Massey. “But the height, like the exposed concrete, is part of the factory aesthetic, and we find it works for our tenants and for us.”

The bottom line, says Massey, is that quality space pays well: “We can charge higher rent, the buildings let so much quicker and we have fewer voids. At White Collar Factory, practical completion was 28 February, and on 1 March we had six lots of fit-out contractors queuing up outside waiting to start work. If you are hitting completion and triggering leases the following day, that's good business.”

Much the same can be said of the exposed concrete frame and soffits. Not only have they become fashionable, they also work practically. “The concrete is structure, cooling system and finish all in one – that's very efficient,” says Massey. “And it's designed to be straightforward to build and simple to install services. It helps with our risk too, because the simpler it is, the more likely contractors are to finish on time.”

And even after completion, the stripped-down style continues to work for developer and tenant alike: “We find occupiers really embrace the ethos of the building. There are not many cellular-type layouts. One of our tenants is delighted he can make eye contact with his whole company from his desk. Moving here was a no-brainer for him.”

Obviously it is too early to predict the demise of the traditional plasterboard office – White Collar Factories are not for everyone. But this simpler style of commercial building certainly looks set to claim a larger market share for some time to come.



the cores are jump-formed,” explains Taylor. “It would not have been practical to have chippies creating beautiful timber formwork every few weeks each time the core rose. So, having chosen our species of timber, and the way we wanted the boards to look in terms of variation and edging, we then had rubber moulds of our perfect wall made by Reckli in Germany.”

The largest wall in the project is some 9m x 6m in the reception area, and so this became the basis for the mould and therefore the repeat pattern – “like wallpaper” according to Taylor, who adds that, unlike timber boards, the moulds can be reused many times and retain a consistent finish. “So it’s much quicker to simply reuse the latex liner every time the core jumps. Of course, we also used it wherever we wanted that board-marked finish.”

This included the ground-floor perimeter walls, the only part of the building to be constructed using self-compacting concrete. While this is commonly specified where there are concerns about the finish, or the complexity of formwork or reinforcement, at White Collar Factory the choice resulted from a programming decision. “It took the walls off the critical path,” explains Taylor. “We wanted to build the first-floor slab early, so of course we could not then pour the walls from above because the slab would be in the way. Instead we pumped into the forms for the walls from below, using self-compacting concrete.”

Whether the visitor is looking at the perimeter walls or those on the cores, the result is a remarkably well-defined board-marked concrete finish. Variations in board thickness, along with the grain of the timber, show through beautifully, and it is clear that using the latex moulds has enabled the construction team to attain that hard-to-achieve paradoxical ideal: consistent inconsistency.

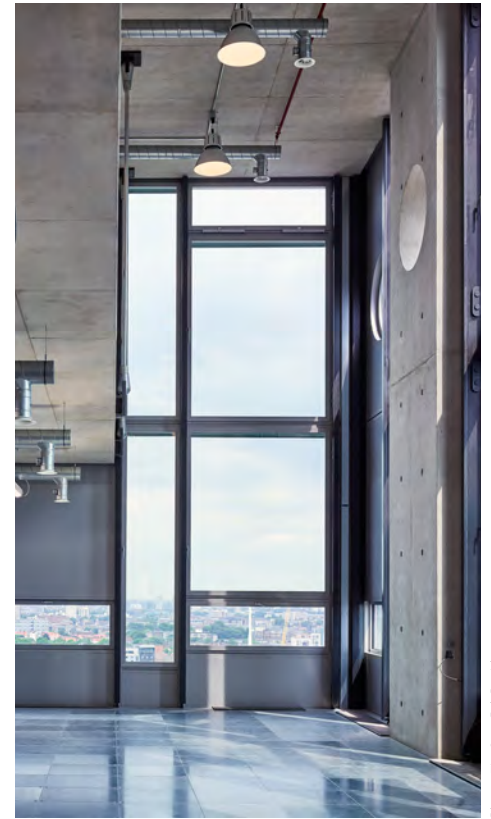

Photos: Tim Soar, Rob Parrish



## Making the Factory fit

In 2008, Derwent London asked AHMM, along with structural engineer AKT II and services engineer Arup, to take the back-to-basics aesthetic to its logical conclusion. What would the perfect stripped-down office space look like? The result of this concept study was a 9m x 9m-grid concrete-framed building with high ceilings, a high thermal mass to minimise heating and cooling requirements – all combined with passive ventilation in the form of openable windows, with the occupant in control.

It meant that when Derwent London acquired the Old Street site, it had the essence of the perfect design ready and waiting. The only trouble was

that the concept study, naturally enough, was for a rectangular building. Bordered by the roundabout at Old Street, the new site, more a rhombus with chamfered corners, was anything but.

“We had to work out how to apply the principles we had developed to an irregular-shaped site,” says the project’s structural engineer, Rob Partridge of AKT II. “It also came with all sorts of local constraints – principally two underground and two mainline railway tunnels.”

Piles sunk from the southern perimeter of the site would have hit the railways, so AKT II developed a solution whereby large, 1.2-1.5m diameter bored concrete piles were sunk some 5m away from the tunnels. Massive 1m-thick full-height reinforced concrete walls in the basements were then used as transfer structures, cantilevering over the top of the tunnels to support the building above.

“This way all the complications happened in the basements,” says Partridge. “From ground floor up everything stacks, with no structural gymnastics. It’s predicated on standardisation, very repetitive, simple and easy to build. It means the building is inherently more flexible for the future because it will be easy to retrofit.”

Because of the basement complexities, the main core to the south was constructed bottom up. “We did this to minimise risk,” says Partridge. “It’s safer to be working in a blue-sky environment when constructing these very large structural elements.”

The less complex, smaller north core was built top-down to save time but both were jump-formed, with the form rising every four to six weeks. “Slip forming wasn’t an option,” explains Partridge. “The drag can leave a messy finish – not what we wanted for the exposed concrete finish around the cores.”

Having dealt with the foundation design, AKT II then started to adjust its generic 9m x 9m grid, looking all the time for structural efficiency as well as simplicity. “Of course, none of the dimensions divided by nine,” says Partridge. “We played around with column positions and ended up with spans of 9-12m – which is a lot for an ordinary-strength reinforced flat concrete slab.”

AKT II could do this, says Partridge, because of extra analysis of the stresses involved, “mapping out slab stresses of several different column configurations in forensic detail”. This gave the engineers the confidence to be less conservative than usual about slab deflection predictions. “We are not scared of doing that – and the result is that as well as reducing the number of columns, those longer spans have created some really nice spaces.”

Partridge is in a unique position to check the long-term accuracy of his computer analysis: AKT II has now relocated to White Collar Factory. “We decided to move in after construction began. It certainly makes it very easy for us to continue collecting information about how the concrete is ageing, both structurally and aesthetically.”





# BACK TO THE POINT

Richard Seifert's masterpiece has been reborn with a new square at street level and luxury apartments behind its iconic cladding. Pamela Buxton reports



**When Centre Point was completed in 1965, it was London's tallest office tower and heralded as an iconic symbol of the swinging sixties. Designed by Richard Seifert for developer Harry Hyams, it was also notable as a pioneer of structural precast concrete cladding.** In the intervening half century, this modernist landmark has had a decidedly chequered history, controversially remaining largely empty but awarded grade II-listed status in 1995 in recognition of its architectural merit.

Now, it is being reborn as a mixed-use development courtesy of an extensive refurbishment by developer Almacantar, which is reviving the complex as part of a new square at St Giles. The project coincides with the imminent arrival of Tottenham Court Road Crossrail station.

It is a highly complicated refurbishment that encompasses not just the iconic tower but the bridge link across St Giles High Street and the adjoining block of Centre Point House. In addition, new-build aspects include the redevelopment of a former pub at the end of Centre Point House as affordable housing, and the creation of a pedestrian piazza by removing the road below the bridge link. Particular emphasis has been placed on improving the base of the tower and introducing new retail and restaurants around the piazza. Rick Mather Architects is leading the design team with Conran and Partners responsible for the residential conversion of the 117m-high tower.

"There was a clear opportunity as the setting was changing from an island in the middle of traffic to public realm," says Gavin Miller, partner at Rick Mather Architects. "The challenge was working out how Centre Point could best activate a new London square."

The practice's strategy, Miller explains, was to treat Centre Point as a heritage building. So how has this concrete complex fared after 50 years? And how suitable is the iconic tower for its new role as chic West End apartments? "I think it has weathered incredibly well," says Miller. "The tower facade has a wonderful finish on the precast concrete. It's been a real joy appreciating how daring the structure was. Everything was really pushed to the limit, especially the bridge link."

Accordingly to Tim Bowder-Ridger, Conran and Partners senior partner and CEO, the tower lends itself very well to residential use, both because of its structure and its West End location. "The principle of the structure – the idea of a concrete-framed building and a concrete envelope that has been designed properly for weathering – was really good," he says.

The tower's floorplates of approximately 30m x 16m, while no longer satisfactory for contemporary office needs because of their low, 2.55m floor-to-ceiling heights, are very well-suited for apartments.

**IT HAS WEATHERED INCREDIBLY WELL. THE TOWER FACADE HAS A WONDERFUL FINISH ON THE PRECAST CONCRETE**

Served by two cores, these will house four 8m-deep apartments on the lower floors, changing to three, two and finally one apartment per floor as the tower ascends, with a 6,000ft<sup>2</sup> duplex at the very top. In total, 82 apartments are being created.

Another advantage was the high level of fenestration within the building envelope, which is formed by 2.6m-wide structural concrete cladding units. Apartments are configured so that habitable rooms are placed around the edge of the plan, all gracing a pair of tall, 2.5m-wide windows. The relatively clear floor spans were another plus – each floor has just four columns in what was originally the central corridor zone, where a 400mm-deep spine beam runs north-south. Particular attention was paid to levelling the floor slab while keeping the new screed as thin as possible, as well as careful integration of new servicing.

While the glazing was upgraded, the precast cladding panels themselves just needed a clean. "There's not that much staining from pollution for a 40-year-old building," says Bowder-Ridger. "We used sodium hydroxide gel and hot water to clean it very gently – we didn't want to lose the aesthetic life of the building."

Important changes are being made at the tower base. Here, the theatrical external staircases have been relocated to inside the building to improve the ground-floor interface, with the original precast concrete treads reused where possible. The rooftop plant room is being relocated to the basement while a health club will be incorporated below the apartments within the original envelope.

One of Rick Mather Architects' main strategies to animate the new piazza was to enclose the area beneath the bridge link. Here, the practice sought to expose and celebrate the original structure, which was formed by post-tensioned concrete slabs at first and second floor levels, cantilevered from six sculptural "blade" columns on the ground floor. New stairs, risers and lifts were introduced through the first and second-floor slabs. The tiled



**ABOVE AND BELOW** Exposed sculptural columns and brise soleil are being restored to create a voluminous space

#### PROJECT TEAM

**Lead architect** Rick Mather Architects  
**Centre Point tower architect** Conran and Partners  
**Structural engineer** Pell Frischmann  
**Main contractor** Multiplex

**OPPOSITE** The former office building is being transformed into a new residential tower with retail, restaurants and a public space at its base







**ABOVE** A lightweight glazed infill is being inserted below the bridge link

finish of the columns was restored along with the original ribbed concrete soffit of the link. Below this, a lightweight glazed infill has been designed to retain the transparency of the original void while creating two restaurant units with sliding 3m-high glass doors onto the square. New terraces are being created on the second floor.

Retail continues around the square on the lower floors of Centre Point House. Here the practice removed a first-floor mezzanine ceiling slab to create a double-height space behind the distinctive brise soleil "ladder" reinforced concrete facade, which has been restored. "This creates a cavernous cathedral-like space that revealed the giant sculptural concrete columns," said Miller. "Wonderful features are still there such as the black floors with cast-in Carrara marble inlays. The plan was to enhance it and make sure we didn't upstage it." Plans have also been drawn up to replace

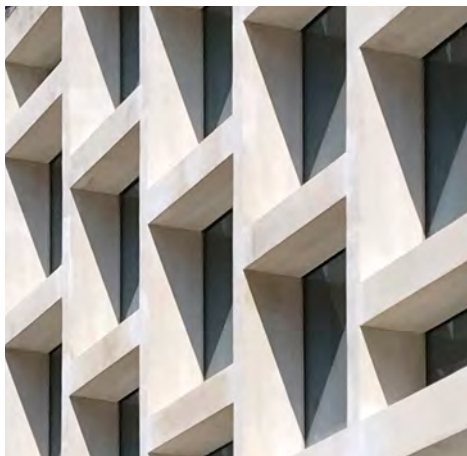

the curtain wall of the upper storeys, which has been altered over the years. This may form a later package of works.

In addition, the architects sought to return both the bridge and first-floor level of Centre Point House to their original pale colouring instead of their accumulated, sooty, dark grey appearance. After researching the original concrete mixes in the archive documentation, the architects discovered that unlike the marble-chip concrete of the tower, these surfaces were coated with hand-trowelled "white terrazzite". This contained fine marble dust which had started to decay. The project team were able to match this accordingly in the restoration.

Alongside Centre Point House, the architects are designing a new build to provide 13 affordable homes over nine storeys above ground-floor shops. The design references the proportions and architectural language of the listed building while ensuring that the new building is heroic enough to stand alongside its esteemed neighbour. This led to the use of 150mm-thick precast concrete panels with insulation supported from the reinforced concrete frame. Rick Mather Architects collaborated on these panels with fashion and textile designer Eley Kishimoto to create a chevron relief pattern inspired by the original concrete mix and patterns of Centre Point tower. Panels next to Centre Point House are colour-matched to the original brise-soleil.

It's been a long haul – Rick Mather Architects was appointed back in 2010 – but construction is now well under way, with phased completion starting later this year.

**LEFT** Materials have been restored across the site, including the facade of Centre Point House

# CENTRE POINT



## Revisit revisited

**Engineer Mark Whitby wrote about Centre Point for CQ in summer 1990. So what does he make of the redevelopment?**

"The building and ultimate listing of Centre Point confirms one's faith in society – what was once derided is now celebrated and finds a new life. The loss of the office use to high-end residential is something I will rue as I had often hankered after it as a potentially perfect office space.

But this new life comes with the opportunity of regaining the space around the buildings and provides a far happier base for the tower. The closing of the road under the link bridge and the completion of the buildings to the south will create a new square to complement Renzo Piano's piazza at Central St Giles just to the east. Unfortunately the two new glass Crossrail entrances immediately in front of the tower have been given a totally gratuitous grandeur that overwhelms the setting, with the result that some of the success achieved by Almacantar and Rick Mather Architects has been lost.

Centre Point provided me with a confidence in what could be achieved with precast concrete, which ultimately found an outlet in buildings such as the offices we designed in Sun Street with Sir Richard MacCormac and in Finsbury Square with Eric Parry. Centre Point reflects the confidence that can be found when the energy of good designers and brave developers is allied with skilled concrete specialists. Issues of cold bridging would make it seem next to impossible today but seeing the new Aria building in Islington by Amin Taha and Webb Yates (surely a future subject for Concrete Quarterly) makes one realise that even this cloud has a silver lining." Mark Whitby is director of engineer Whitby Wood



# WAFFLY GOOD

Restored ceiling waffle slabs are the signature design feature in a stunningly reimagined 1980s office. By Will Mann

For its clever £5.6m refurbishment of 45 Folgate Street in Spitalfields, London, architect TateHindle has retained many original features of what was a tired 1980s office, most strikingly the exposed concrete waffle slabs of the ceiling. These combine with the bare columns of the structural frame to create a stripped-down, "industrial aesthetic", as project architect Tony Lee puts it.

The five-storey building sits on a cobbled street of mostly Victorian facades. The design retains the brick facing of the front elevation, with new window bays on ground and first floors, plus a modernised entrance, allowing more light into the interior. The core has been reconstructed, with one of two staircases removed, the fifth-floor roof space remodelled, and a stepped extension added to the rear. The lettable space has been increased by over 25% to 1,925m<sup>2</sup>.

Previously, the waffle slabs were concealed by suspended ceilings, and the square coffers, each 850mm across and 275mm deep, were in surprisingly good condition. "Half a dozen per floor had holes around 100mm in diameter drilled through for services, and roughly one in 20 had yellow paint sprayed on," says Lee. "To fill the holes, we created a special mould and poured in the concrete from above. We tested half a dozen samples in advance to achieve the right match." The yellow paint was blasted off but otherwise the slabs were just brushed clean, and small imperfections were left to give a natural effect.

The grid pattern of the waffle slabs is accentuated by strips of LED lighting, suspended from the ceiling, except in the reception where it is attached to the soffit. "The LED lights give a stronger output, which meant we could space them further apart," explains Lee. "By suspending them, we could also create an upright on the ceiling, brightening the appearance of the waffles."

The high-level services are concentrated around the edges of each ceiling to expose as much of the soffit as possible. Removing the suspended ceilings gained an extra 375mm of space, to give a total floor-to-ceiling height of 2.85m.

Various concrete features have been added to complement the structural elements, including sinks in the bathrooms and, in the reception, the

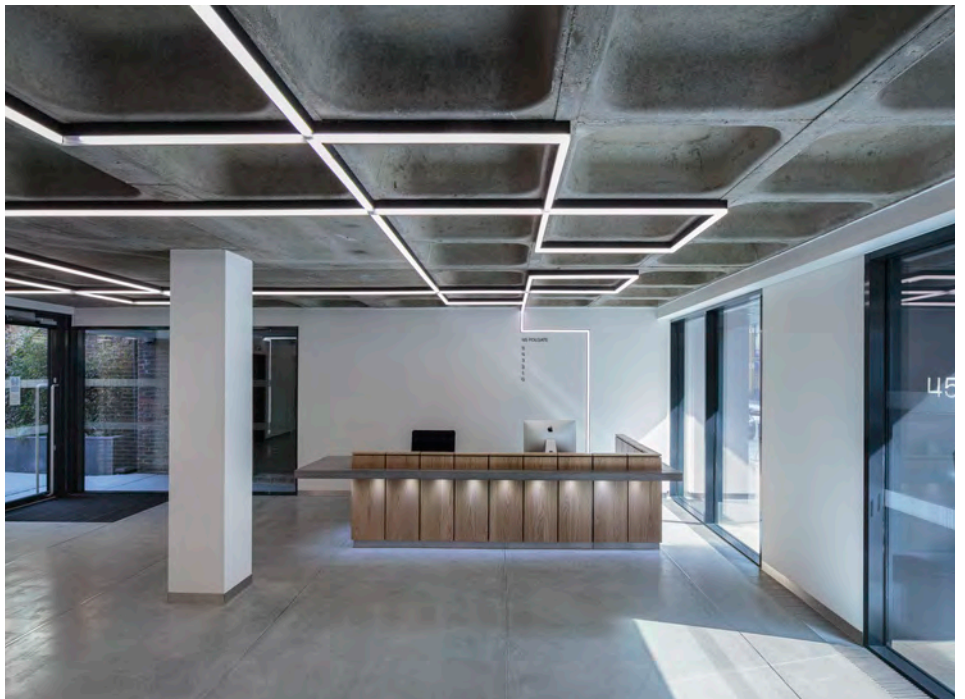

desktop, a cantilevered bench and a polished concrete floor.

"To avoid inconsistency in the floor's appearance, we used metal trims over the joints, 1,500mm apart, which also reinforces the modular effect of the waffles above," explains Sarah Brown, project director at TateHindle. "Simplicity is the theme of all the finishes. So we have used black metalwork, white porcelain, stainless steel and timber, which complement the concrete."

As the nearby White Collar Factory by AHMM (see pages 4-7) attests, industrial chic is a very popular aesthetic among the district's hi-tech start-ups, which are the development's target tenants. 45 Folgate Street shows that older buildings can do it just as well as new ones.

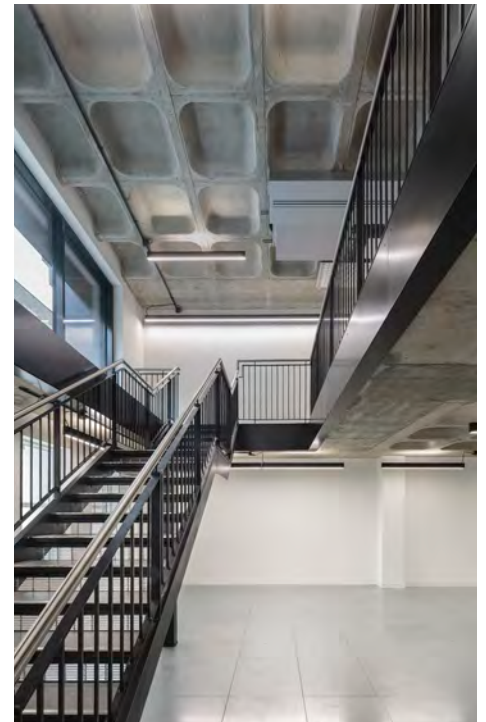

## PROJECT TEAM

**Architect** TateHindle  
**Structural engineer** Sinclair Johnston  
**Main contractor** Corley + Woolley

## CLOCKWISE FROM RIGHT

The grid of waffle slabs is emphasised by strips of LED lighting; the existing coffers were mostly just brushed clean; the brick-clad front elevation has been retained







# MASTERS OF MASS

Few architects have contributed more than Bennetts Associates to the renewed popularity of exposed concrete. Nick Jones met directors Rab Bennetts and Simon Erridge

**It may come as a surprise to learn that workplace wellbeing was born on a business park outside Coventry.** It was here, in 1991, that Bennetts Associates designed what was only its second major project: a headquarters for the newly privatised energy company, Powergen.

The practice took a seminal approach to energy efficiency, pulling out all the stops to show that good design could create a comfortable environment just as effectively as heavy servicing. Narrow office floors were flooded with daylight, ceilings were high, windows were top-hung and openable for natural ventilation, and the facade was carefully designed to provide solar shading. One of the most significant elements were the profiled exposed-concrete floor slabs which, combined with night purging, stabilised internal temperatures through their high thermal mass.

Powergen set a template for much of Bennetts' subsequent work, which in turn has had a massive influence on the resurgence of concrete as both a structural and aesthetic material – it could be argued that neither the White Collar Factory

nor 45 Folgate Street, featured elsewhere in this issue, would have been designed in quite the way they have without Bennetts' pioneering work on concrete-framed offices in the 1990s and early 2000s. It is one of the reasons why the practice's founder, Rab Bennetts, was the obvious choice to speak at CQ's 70th anniversary celebrations in September, and why we caught up with him and fellow director Simon Erridge at Bennetts' Clerkenwell HQ earlier in the summer to reflect on the practice's past, present and future.

Bennetts first began thinking about energy efficiency and thermal mass during the 10 years he spent at Arup Associates in the late 1970s and 1980s, but it wasn't until he and his wife Denise set up their own practice in 1987 that they "started to push those ideas a bit". When the Powergen job came four years later, it was the opportunity they had been waiting for. "That was a bit of a breakthrough, and a lot of our early convictions were born in that building," says Bennetts. "Powergen took the view that they should be efficient with their own product, which was admirable, so we ended up looking at thermal mass in more detail."

The practice collaborated with the services engineer Nigel Griffiths, who provided "real rigour in the analysis of the building, which is what we'd been missing up to that point". This was all the more important as it was Bennetts' first design-build project, placing the young practice under contractual obligation to prove that natural

ventilation would work without reducing comfort levels. Use of computational fluid dynamics, then in its infancy, proved the cooling benefits of wind pressure across clear floorplates; equally close attention was paid to the profile of the vaulted structure, which was deepened to increase the exposed area of thermal mass and elegantly tapered towards the source of daylight.

But Powergen would not have had the impact that it did if it had just been about efficiency. Twenty years before anybody had coined the phrase "wellbeing" in relation to offices, this was essentially what Bennetts was doing. "You could only do it if it was comfortable, otherwise people wouldn't accept it. So the analysis of temperature was massively important. Then there were visual stimulants, views, the ability to open your own window – all that stuff is now called wellness."

For Bennetts, these ideas were also in part a "Trojan horse", in an era of postmodern glitziness and Prince Charles-inspired classical facades, for the modernist ideal of an expressed structure. Structure and quality of space were, he argued, inextricably linked. Describing Powergen in CQ in the winter of 1991, he wrote: "The deadening effects of flat suspended ceilings have been avoided and the structure will resume its natural status as the means of providing shape and form to architectural space." This may not sound radical today, but for the times it was something like a manifesto.

The practice quickly gained an impressive client list, with whom it could continue to hone its approach. In the wake of Powergen, Bennetts

**OPPOSITE** The vaulted soffits at Powergen increased the area of concrete that could be exploited for its thermal mass

Jubilee Library in Brighton brought a similar approach to a very different building type

**BELOW LEFT** Double-height structural "trees" at the

**BELOW** At New Street Square, Bennetts created public space in a dense part of the City





adopted similar principles on headquarters buildings for John Menzies (1993) and BT (1996), both in Edinburgh, and Wessex Water (1998) near Bath. “They were all looking for this stuff and we were just about the only practice who had done it on this scale. Other architects had done good work on sustainability, but we had actually built this bloody great big building,” says Bennetts.

They explored the same techniques in other sectors: Hampstead Theatre (1994), the practice’s first theatre project, employed displacement ventilation below the auditorium seating. And at Brighton’s Jubilee Library (1999), it incorporated high levels of thermal mass into a large public space through a dramatic arrangement of concrete structural trees. Not for the first time, this project depended on Bennetts’ trademark blend of rigorous analysis and commercial nous. This was the heyday of PFI, a procurement route that tended to favour cost-cutting over good design, which meant that the developer “started chopping out the nice bits. They said, you can cut down the concrete, make it GRP, do something with the glazing. So we had to prove to them that if we did that, the building wouldn’t work. We showed that it would add more running costs, which for PFI is not good.”

If PFI clients were hard to win over, another sector was proving equally resistant to change: traditional London offices. Until the mid-2000s, Bennetts’ commercial clients tended to be end users in discrete buildings away from the urban centre. In the city, the look was still decidedly corporate.

**FOR THE SIZE OF THE FLOOR PLATE, THE BUILDING HAS 1.4 TENNIS COURTS MORE SURFACE AREA THAN FLAT SLAB CONSTRUCTION**

**CLOCKWISE FROM ABOVE**

The Royal College of Pathologists – the concrete frames helps to establish a “sense of permanence”;

the deeply coffered soffits show the influence of Powergen; immaculate board marking on the interior walls

“The speculative office market never really accepted these ideas,” says Erridge. “It has taken 20 years for them to filter down to the mainstream.”

A turning point was New Street Square (2002), the first BREEAM Excellent-rated building in the City and its largest concrete-framed development for many years. Post-tensioned concrete floor slabs offered the potential of a thermally massive structure while reducing the quantity of concrete required, and the whole scheme was designed with flexible, expansive floorplates so that the complex could be adapted to unforeseen future uses. This was a lesson that Bennetts had learned from the failures of the post-war modernists, whose rigid designs are often difficult to adapt to highly serviced, computerised workspaces.

New Street Square may have heralded a new era of sustainable speculative development, but one thing hadn’t changed. Just as at the Powergen and Wessex Water buildings, where the internal exposed structure was painted white, the concrete aesthetic was greeted with a certain degree of ambivalence. Many original tenants still opted to fit out their offices in a conventional corporate style, with high-level servicing concealed by a suspended ceiling, rather than benefit from the exposed slab.

If the same tenants moved in tomorrow, you suspect they might make a different decision. Over the past decade, exposed concrete has become a desirable workplace look – and a key reason for this is the association with wellbeing and sustainability.

Perhaps unsurprisingly, the practice’s current work embraces this trend. The Royal College of Pathologists in Aldgate, east London, employs a language of crafted concrete throughout the

building. Walls are lightened by ground granulated blast furnace slag and beautifully boardmarked – the handiwork of contractor Gilbert Ashe, which was also responsible for the superb finishes at Haworth Tompkins’ Stirling Prize-winning Everyman Theatre in Liverpool. And the various spaces are united visually by a deeply coffered soffit – a direct descendant of the vaulted ceilings at Powergen. “It’s picking up on the lessons we learned from those early buildings,” says Erridge. The coffers give extra height to the spaces, and increase the area of exposed concrete: “For the size of the floor plate, the building has 1.4 tennis courts more surface area than flat slab construction. So you’re able to energise that concrete, and use it through night-cooling to improve the thermal performance of the building.” Moreover, by using less concrete than a typical floor structure, “you’re able to save the weight of 51 Asian elephants”.

Impressive though these figures are, at the Royal College of Pathologists it is the character imbued by exposed concrete that is the material’s most important attribute. “They’re building a headquarters that they want to stay in forever. This is their permanent home,” says Erridge. “The building had to be contemporary but it had to have a degree of gravitas and permanence that concrete could bring, and would be difficult to do with things like suspended ceilings. It had to look like a substantial new HQ for a royal college.” For now, Bennetts seems to have won the argument about expressed structures – his Trojan horse has well and truly breached the barricades.





# LASTING IMPRESSION

## GAVIN MILLER

### FROM THE DEPTHS OF THE OCEAN TO THE TOP OF LONDON



The Romans built some amazing concrete buildings, but the best Roman concrete is underwater, used to form breakwaters for harbours. Researchers at the University of Utah have found that it's superior to most modern concrete in terms of durability. Instead of using Portland cement, the Romans mixed baked limestone and seawater with volcanic ash, which reacts with seawater to become stronger – another example of Roman innovation that could inform more environmentally friendly mixes today.

The Glenfinnan Viaduct in north-west Scotland **1** was completed in 1901, but it's also Roman in the sense that it's mass concrete rather than reinforced. I love the solidity of the arched forms, and the curve gives it a real presence in the landscape.

The Rue Franklin apartments in Paris by Auguste Perret **2** (1903) was one of the first uses of a concrete frame. It's quietly beautiful, the way it integrates the structural frame with the infill panels, and the contrast with the decorative elements. I like the innovation of the building plan, with flexible spaces and an inverted bay window that brings light into the rooms. It's a very humane and urbane use of concrete.

For me, Oscar Niemeyer's Casa de Canoas **3** (1954) in Rio de Janeiro is the original plastic use of concrete. It has a free-form oversailing roof slab, which provides shade to the spaces below, but the glass doesn't follow the form of the roof above and it integrates with the landscape, so you get a wonderful merging of inside and outside.

A lot of people think that Richard Seifert's Centre Point **4** (1966) is a Brutalist building, but it's much more luxuriant than that – it's more in the vein of Niemeyer or Pier Luigi Nervi. There's only board-marked concrete where you're not meant to see it, otherwise there's a deliberate treatment to it. Sometimes concrete is used daringly, pushing it to the absolute limits, and in other areas it's quite flamboyant. The more I've got to know the building as we've led its refurbishment, the more I've appreciated it.

**Gavin Miller is a partner at Rick Mather Architects**

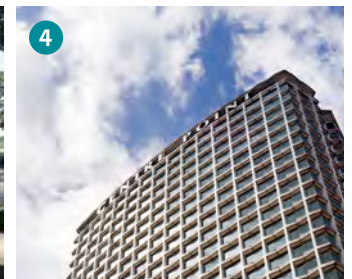
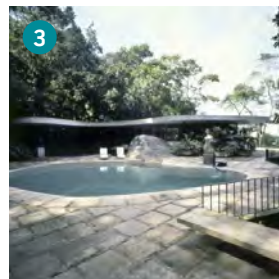

Photos: 1. Niclas17/CC BY-SA; 2. seier/seier/CC BY; 3. Michel MoehArmedial/VIEW; 4. Paul Grundy

## FROM THE ARCHIVE: SUMMER 1981

### CLOVER OVER THE CITY

At 183 metres and 52 floors, Richard Seifert's Natwest Tower was the tallest building in Britain when it was completed. But this modern engineering triumph did not chime well with the mood of the time: the office block was "an unfashionable building type", noted CQ, and in the wake of "ill-fated tower blocks of flats", all towers were now viewed with suspicion. Centre Point, arguably Seifert's finest building, had only just found an occupier 13 years after its completion. And the romance of high-rise commercial architecture had definitely fizzled: where the tapering plan of Centre Point had appeared sleek and modern, the Natwest Tower's clover-leaf shape based on its client's logo just seemed nakedly commercial.

Nevertheless, CQ still found plenty to like in the Natwest Tower, a "gleaming and sophisticated presence in the City", it concluded. "The towers that have come from the offices of Richard Seifert and Partners over the last two decades will probably go down not only as the most handsome office towers that the twentieth century ever built but also as the most striking contribution of the century to London's skyline."

**This year CQ is celebrating its 70th anniversary. Find out more, and access the full archive, at [www.concretecentre.com](http://www.concretecentre.com)**

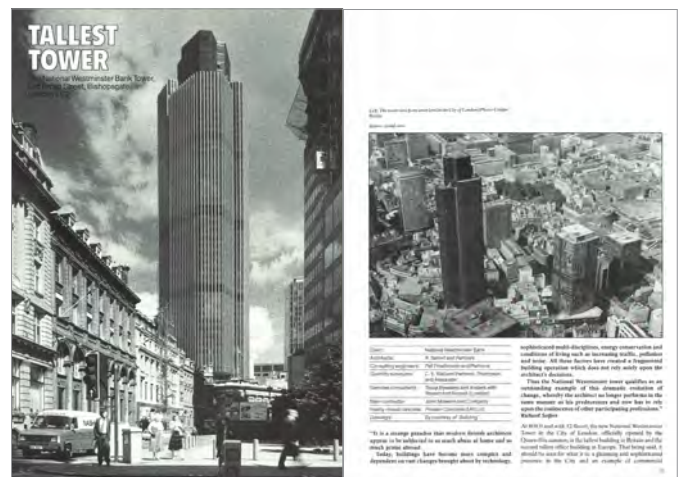



# FLOORING IT

Elaine Toogood shares her specification tips for achieving top-notch polished concrete floors

**It sounds like a simple matter to describe the type of smooth concrete floor finish that you wish to achieve, but there are a number of variables to consider.** Diamond-ground polished concrete floors are ground progressively smoother, a process which removes the surface of the concrete. The aggregate is usually exposed, the extent and size depending on the depth of surface removed. Alternatively, power-trowelled floors are also referred to as polished concrete, but give a smooth, dense surface and a “solid” colour finish with minimal aggregate exposure. Each requires a significantly different specification and installation and, importantly, has different programming implications.

Below is a set of key parameters to achieve best results:

- Establish your aesthetic and visit examples to benchmark the type and quality required, bearing in mind that every polished concrete floor has a unique finish with variations across its surface.
- Consider its function and likely maintenance regime. An industrial floor with wheeled traffic, for example, is likely to require greater crack control.
- Where aesthetics are important, appoint a specialist installer to carry out the work and seek pre-tender advice. Most contractors have their own specification and method statements adapted to suit project particulars, including the concrete supply – because control of the delivery and quality of the concrete is critical. Typically the concrete should have a minimum 350kg/m<sup>3</sup> CEM I, with well-graded aggregates.
- For diamond-ground floors, the choice of aggregate is critical to the appearance and options should be discussed with the specialist installer. Unlike terrazzo floors, uneven aggregate distribution should be expected.
- Allow 100mm depth for an unbonded concrete

topping (screed) to reduce risk of curling. If heating pipes are embedded, this depth is to the top of insulation, ie it includes the depth of the pipes.

- Don't be too specific about the exact shade of grey of the floor. This will save time and cost. Colours vary around the country depending on source of local natural materials and colour of cement. The process of burnishing or trowelling also changes the tone when compared to a formed face cast using the same mix.

- If you want to be specific about the tone or colour, consider using pigmented dry shake toppings. These proprietary powders combine surface hardeners, cement and pigments and are broadcast onto the fresh concrete to be floated or trowelled in. They can be specified to any RAL colour but there will still be tonal variation in the surface, as with any concrete surface. It is also possible to add pigment to the mix to provide a through colour. This is worth considering for a ground polished floor or where steps or other formed features are incorporated into the design.

- Concrete shrinks as it cures, so non-structural cracks are to be expected. To minimise cracking, joints should be created either using screed rails to isolate areas of pour, or by saw-cutting into the concrete afterwards to induce crack location.





**CLOCKWISE FROM LEFT**

At the Andipa gallery in Knightsbridge, contractor Lazenby installed an Off White concrete floor, finished with a satin sealant and a matching mastic colour in the joints; Highly polished concrete floors complement a roof extension made from shipping containers at the Irving Place Carriage

House in Brooklyn by Lot-Ek; McLaren Excell's Kew House in London has polished concrete floors throughout the interior; At Christ & Gantenbein's extension to the Swiss National Museum in Zurich, the floors were given a deep polish to resemble the terrazzo finishes of the original 19th-century galleries

workmanship. Diamond grinding takes place once the concrete is sufficiently cured, nominally after about a month.

- The time taken to trowel or grind any floor will depend not only on area, but on the length of perimeter walls, where smaller equipment is needed. Ideally internal walls should be installed after the concrete is complete. It is worth noting that skill is required to limit the visual impact of different tools, and a difference in finish around the boundary is to be expected. A dry shake finish produces less tonal variation.

- Recessed door tracks and floor boxes are best

installed after the concrete floor, using knock-out ply-box spacers to create accurate voids in the floor. Attention to detail at thresholds is essential.

- Once the floor is polished or trowelled smooth it will be left to cure. Some installers favour whole-room curing; others place mats on top for protection. The timing of each is critical and should be discussed with the contractor and programmed in advance. Be aware that any isolated item placed on fresh concrete can create a permanent dark patch due to differential curing.

- Finally, the floor should be sealed to improve maintenance and possibly enhance the sheen.

Designers should provide design intent drawings for discussion with installers. A useful rule of thumb for 100mm depth is to place a joint at approximate 4m centres, ideally creating as square an area as possible. Joints should also be placed to separate areas that are likely to dry at different rates, such as dog legs, ingress corners or between shaded or sunny areas. Underfloor heating needs to be commissioned at a steady slow rate, but only once the concrete has cured sufficiently. Anything that might inhibit shrinkage could lead to cracking so attention is required to perimeter details and any abrupt variations under the concrete. Reinforcement mats (mesh) can help limit cracking and sometimes fibres are used. Proprietary low-shrink mixes are available.

- Joints can be left as a shadow gap or filled afterwards with steel or brass rods or more commonly with flexible grout or mastic. Linings can hide the perimeter isolation gap at wall junctions.

- Since power trowelling takes place within hours of the concrete floor being placed, planning and timing of operations is essential. Careful scheduling, usually with early morning pours, will help reduce the need for power trowelling late into the night with the associated risk of sloppy

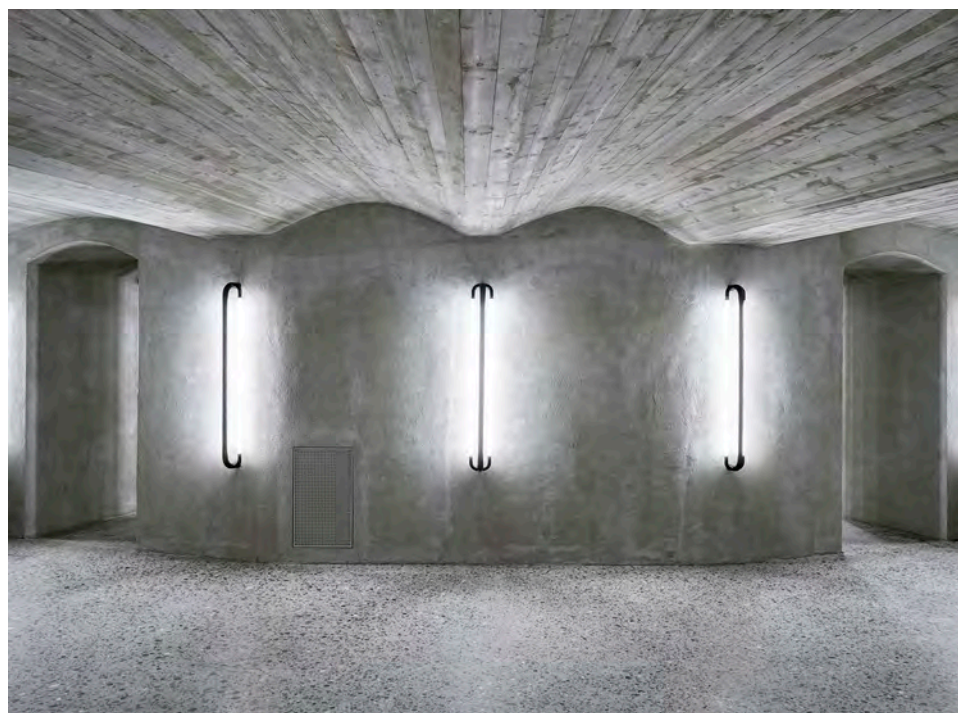





ABOVE Facing wall to a contiguous piled wall

# DESIGNING CONCRETE BASEMENTS

Charles Goodchild outlines the main considerations for the structural design of subterranean spaces

There are many ways of constructing basements, with many complexities and specialities. This article will outline some of the key considerations for their structural design. A successful basement is a collaborative effort, so the whole project team should be engaged in their delivery.

## Construction types

BS 8102:2009 defines three main methods or basement construction types for providing protection against ground water:

■ **Type A** Barrier or membrane protection with a waterproofing layer located either externally, internally or sandwiched within a structure of reinforced concrete or masonry.

■ **Type B** Structural integral protection: reinforced in-situ concrete is designed to be water-resistant by controlling any cracking and using tried-and-trusted details such as water bars.

■ **Type C** Drained protection: an internal cavity system, which allows any water seeping through external walls and floor to drain to a sump and be pumped away.

BS 8102 also divides basements into three grades of internal environment and gives associated illustrative building uses:

■ **Grade 1** is for where some seepage and damp patches are tolerated, such as car parks.

■ **Grade 2** allows no water penetration, but some damp is tolerable and some ventilation may be required in permanent workshops or garages.

■ **Grade 3** is where no water penetration is tolerated, and ventilation, dehumidification or air conditioning is required. This grade is appropriate for residential or commercial accommodation.

The choice of protection type is heavily influenced by the client's needs, in terms of the grade of basement, and an assessment of site conditions and the risks from groundwater. It may determine whether a combination of construction types is sensible – this is relatively common and is an NHBC requirement. Based on the water-table level, BS 8102 contains advice, summarised in table 1.

Type A will require specialist advice in all but the most benign conditions. Type B is water-resisting reinforced concrete construction and will most likely form part of the structural engineer's brief. The structural engineer is also likely to be involved with larger Type C basements because one of the prerequisites is to use the outer structure to keep water out of the cavity as much as possible.

## Surveys and initial feasibility studies

Generally, layouts should be as simple as possible. Aligning the basement with the superstructure (or vice versa) simplifies construction.

An appropriate site investigation and thorough evaluation of its findings is an essential part of any basement design. A major part of that is to determine the groundwater level, which affects both the choice of construction type and the risks during construction. Besides its influence on the type of protection, a high water table means buoyancy, lower soil strengths, high lateral pressures, potential flooding and, probably, a difficult and muddy site. During construction, water levels can be managed with pumping and cut-off walls but these require space and permissions.

On rural and residential sites it may be sensible



to batter the sides of the excavation. On many urban sites any basement usually extends to the site boundaries and care will be necessary when working close to adjacent structures – party-wall agreements may be required. Care should also be taken over any adjacent services or tunnels.

There are many ways of temporarily supporting basement excavations. Piled walls are popular as they can be incorporated into the permanent works. Sheet piling is not as popular as it once was and concrete piles are now used extensively. Contiguous (ie, spaced) piles can be used to retain soil while additional secant (overlapping) piles help to seal off groundwater and/or unstable ground. On anything other than a dry site, these walls will need a second line of defence – such as a membrane, a lining wall, a facing wall or a drained cavity.

Cantilevering piles will make construction simpler, but at depth, propping, with associated capping beams, wallings etc. gives greater overall economy. At even greater depths, diaphragm walls can be necessary – but the costs become huge.

Continuity of the defence system(s) is essential. One leading contractor does all work in BIM, making sure that at least two completely continuous waterproofing layers can be demonstrated and that problem areas such as service entries and corners are thought through before going on site. Designers also have to consider water run-off from surfaces and cavities above.

The correct specification and installation of the waterproofing system or systems is fundamental to success. It will be useful to talk to specialists. The websites of the Basement Information Centre and the Property Care Association contain useful information and details of specialists who can help with specification and details. BS 8102 emphasises the inclusion of a specialist waterproofing adviser on the design team.

By considering all these issues, feasible construction methods should emerge and scheme designs can then be developed and discussed with the client and design team and, hopefully, the constructor. Generally, costs increase with depth: costs increase significantly with high groundwater.

Risk associated with water table	Water table classification	Type A	Type B	Type C
			Reinforced concrete wall	Piled wall
High	High	✓??	✓	✓ <sup>2</sup>
	Variable	✓?	✓	✓ <sup>2</sup>
Low	Low <sup>4</sup>	✓	✓	✓

?? Seek advice: cement renders may be appropriate  
 ? Seek advice

✓ Appropriate – given correct design and construction

<sup>1</sup> Drainage and/or a membrane to the outside of a reinforced concrete wall will lower risk

<sup>2</sup> Piled walls should be repairable or have a membrane

<sup>3</sup> The more the outer wall can be made impermeable, the lower the risk. Drainage of cavity needs maintenance

<sup>4</sup> To be classified as "low", the water table must be permanently below the base slab, but for free-draining strata only

Based on BS 8102, table 1

## Structural design

The structural design of concrete basements considers both the ultimate (strength, equilibrium, geotechnical) and serviceability (deformation and cracking) limit states. For reinforced concrete basements, it's not the concrete that leaks, but cracks, construction joints and the results of bad workmanship. Provided that the appropriate concrete and other materials are specified and workmanship can be assured, structural design is mainly about controlling crack widths.

Having said that, the ultimate limit case must be considered for the various loads and load combinations according to the rules in Eurocodes 2 and 7. Normally, slabs have permanent and imposed actions and may be subject to heave; walls have pressures due to imposed load, retained soil and/or compaction on the walls. And, of course, water pressure affects both.

Serviceability design is mainly about crack control. When concrete sets it is usually warm due to the heat of hydration. When it then cools, the concrete will try to contract. If that contraction is restrained by, say, a wall sitting on a base or slab, then the wall will experience tensile stresses in areas of restraint. Those tensile stresses may be sufficient to cause through-cracking and the width of those through-cracks must be controlled to accepted limits using reinforcement. These early-age thermal effects are often critical. Longer term, seasonal temperature effects and, in dry basements at least, drying shrinkage set up tensile stresses in the same way and may be more critical. The same phenomena occur with any adjacent slab or wall pour, but they become critical in basements and water-retaining structures.

In calculations, designers usually deal in strains, rather than stresses. Strains due to the additional short (early-age), medium (seasonal) and long-term (drying) effects are added. The total strain is then compared to the concrete's time-dependant strain capacity to determine whether the section is likely to crack or not. With reasonably thick sections, it is usually found (or, as a reasonable worst case, assumed) that the section will crack. The calculated strain is used to determine how much reinforcement is required to keep any cracks to an acceptable theoretical width.

Another check ensures that the reinforcement will not yield at the first crack – it is desirable to have lots of small cracks rather than a large, uncontrolled one. This minimum reinforcement can be about 0.58% to Eurocode 2. If there are truly stiff restraints either end of a section then this "end restraint" condition results in even greater reinforcement requirements.

Design crack width limits depend on the water table. Eurocode 2 is not that helpful but guidance is given in The Concrete Centre publication, Concrete Basements. For Type B protection, a through-crack width limit of 0.30mm may be appropriate where the water table is low, 0.2mm where it is variable and 0.05-0.20mm where it

FIGURE 1: TYPE A WATER-RESISTING CONSTRUCTION (BARRIER PROTECTION)

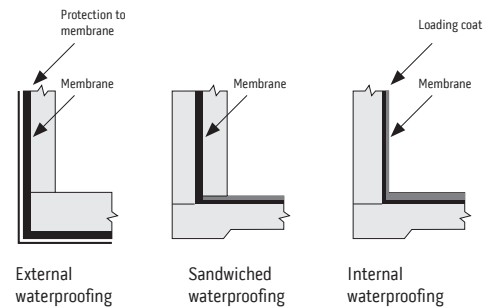

FIGURE 2: TYPE B WATER-RESISTING CONSTRUCTION (STRUCTURALLY INTEGRAL PROTECTION)

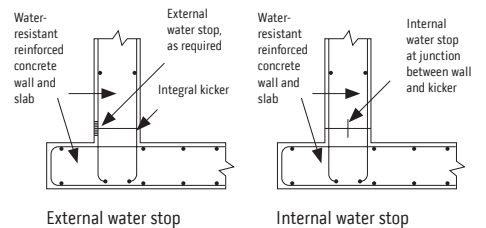
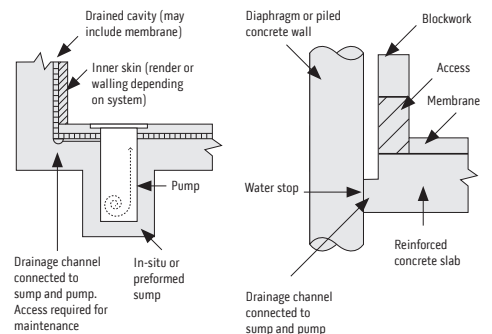

FIGURE 3: TYPE C WATER-RESISTING CONSTRUCTION (DRAINED PROTECTION)



is high. High water tables can mean potentially punitive amounts of reinforcement.

For Type A protection, the structure itself is not intended to be watertight: masonry is often used. Where concrete is used, then a maximum 0.3mm through-crack width should be acceptable to the membrane. In Type C protection, 0.3mm may be appropriate although 0.05-0.2mm will improve overall water resistance.

Traditionally, it is usual to deal with flexural crack widths separately. These cracks are limited to the usual 0.3mm at the surface. However, as they only go part-way through the section, it is assumed that they do not impair water resistance.

## Further reading

Concrete Basements, published by The Concrete Centre, available from [www.concretecentre.com](http://www.concretecentre.com)



## FINAL FRAME: KATYN MUSEUM, WARSAW

Commemorating the massacre of 21,000 Polish officers by the Soviet secret police during the Second World War, BBGK Architekci's museum is split across three buildings in Warsaw's 19th-century citadel. One of the most powerful interventions by the architects is a chasm between two vast red-pigmented concrete walls that leads visitors down to the exhibition space. The project was shortlisted for the 2017 Mies van der Rohe Prize.

